

Caratteristiche tecniche	
Pressione max.	250 bar
Portata max.	80 lt/1
Peso	2,7 Kg
Materiale collettore	Alluminio
Attacchi A / B	3/4" G

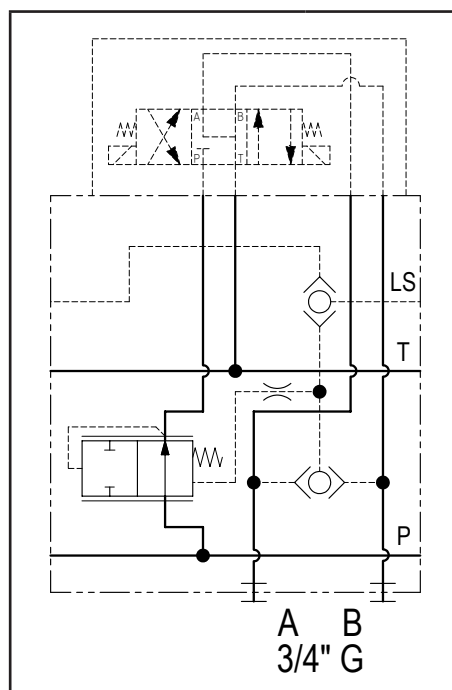
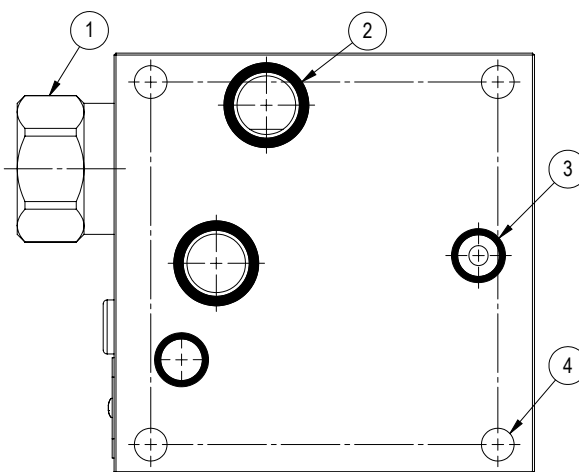
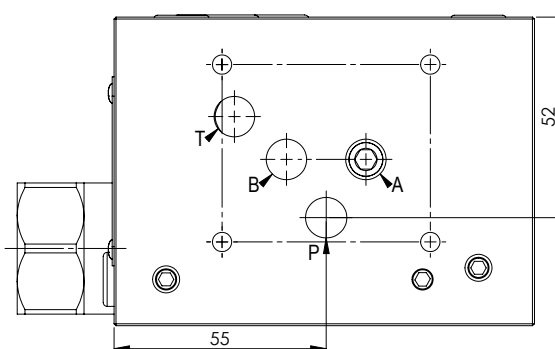
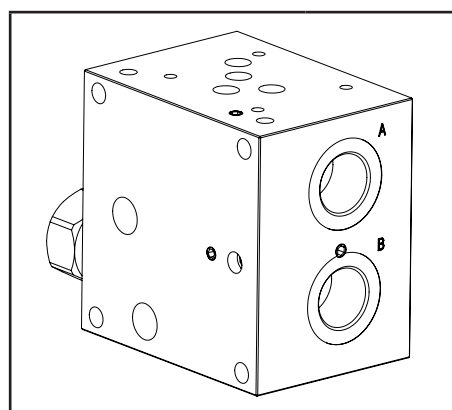

N°	Descrizione	Q.tà
1	Compensatore molla 5,5 bar	1
2	OR 3068 Ø i. 17,12 filo 2.62 (P-T)	2
3	OR 2043 Ø i. 10,82 filo 1,78(LS-FS)	2
4	Foro passante Ø 8,5 per tirante	4

Codice d'ordinazione

H	5	2	1	3	A
---	---	---	---	---	---

**Prodotto Hydrover****Materiale collettore**  
Alluminio**Serie prodotto**Serie 52 - Elementi componibili LS per valvole Cetop 5  
in circuito parallelo**Indice prodotto**